



Visite la página TRAXXAS.com/manuals para descargar el instrucciones en su idioma.

Auf TRAXXAS.com/manuals können Sie anleitung in Ihrer Sprache downloaden.

Maxx Series Big Bore Shock Installation

Fill the Shocks with Oil

Remove the upper shock cap. Fill the shock with oil until it is about 3/4 full. Slowly move the piston up and down (always keeping it submerged in oil) to release the air bubbles. Finish filling the shock until the oil level is 1.5mm from the top edge of the shock body. Allow any remaining air bubbles to surface; then, screw on the upper shock cap.

Tighten the upper cap only finger tight. Over-tightening may damage the rubber diaphragm and cause leakage. Exercise the shock. It should operate smoothly and quietly. If it squeaks, remove all trapped air bubbles in the shock body by removing the upper cap and allowing the bubbles to surface and break.

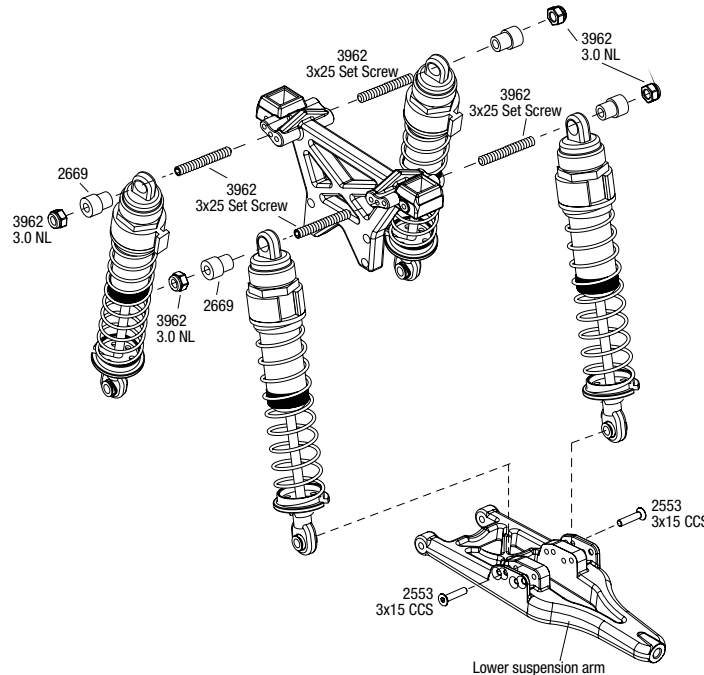

Covers Part #4962

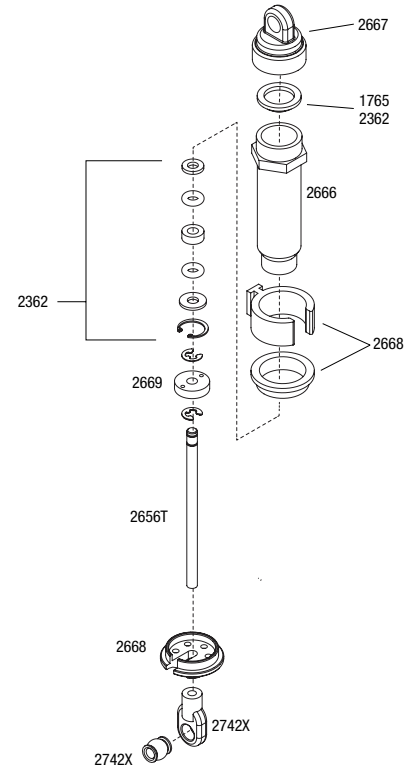

If you have questions or need technical assistance, call Traxxas at

1-888-TRAXXAS

(1-888-872-9927) (U.S. residents only)

TRAXXAS.COM

Traxxas, 6200 Traxxas Way, McKinney, TX 75070, Phone: 972-549-3000, Fax: 972-549-3011, e-mail: support@Traxxas.com